



INSTRUCTION MANUAL

FOR

CHEVROLET APPLICATIONS **(including LT-1)**

Cleveland, Ohio
216.398.8300
www.mrgasket.com

Installation Manual For The ACCEL Digital Fuel Injection Engine Management System

***Prior to starting the installation of your ACCEL/DFI system,
read this manual carefully!!***

Contents	Page Number
Introduction	2
I) Obtaining Your Manifold	2
II) Setting Up Your Manifold	3
III) Mounting Your ACCEL ECM	3
IV) Injector Harness Installation	4
V) Main Wire Harness Routing and Connections	4
VI) Choosing Your Distributor	5
VII) Fuel Pump Mounting and Fuel Line Installation	6
VIII) Mounting The Oxygen Sensor	8
IX) Air Cleaner Assembly	7
X) TPS Adjustment	9
XI) Starting the Vehicle	9
XII) Optional Items	10
XIII) Trouble Shooting Guide	11

***Some parts are not legal for sale or use in California
or on any pollution controlled motor vehicle.***

INTRODUCTION:

CONGRATULATIONS! You have just purchased the finest engine management system available. Fuel injection control is an exact science that ACCEL has made simple. This manual is written to assist you with the installation of your new system. Please read the manual carefully.

Prior to starting your installation, please verify the contents of your ACCEL/DFI package. You should find the following components:

- Electronic Controls Module (ECM)
- Main Wire Harness (MWH)
- Injector Wire Harness (IWH)
- Manifold Absolute Pressure (MAP) sensor
- Heated Oxygen Sensor with mounting nut
- Coolant Temperature Sensor (CTS)

***If you are missing any item,
please contact your dealer immediately.***

Although the package you just received is designed to allow you to convert a carbureted engine to fuel injection or allow you better control over your present fuel injected engine, it does not include the hydraulic portion of the installation. If you need a fuel pump, filter, fittings, etc. Contact your ACCEL EMIC center for the proper ACCEL/DFI part numbers for your application.

I – OBTAINING YOUR MANIFOLD

ACCEL/DFI has a number of fuel injection manifolds for small block and big block Chevrolets available. With a growing selection of manifolds, ACCEL/DFI should be able to satisfy almost any engine combination. For the combinations that would not be satisfied by our proven manifold designs, including applications not covered, ACCEL/DFI has the hardware necessary to modify a carbureted style intake for multi-port injection. Contact a dealer or reference our catalog for part numbers. ACCEL/DFI also has Engine Management Installation Centers (EMIC) that can not only install and tune your system but many can also fabricate or modify an intake for you as well. For the nearest EMIC to you call: 1.800.992.2235.

II – SETTING UP YOUR MANIFOLD

Prior to installing your manifold make sure that gasket surfaces are clean. ACCEL recommends using a 180 degree thermostat. Place your thermostat and gasket onto your manifold, put your thermostat housing onto the manifold and bolt in place. If your are using TPI manifold, whether it is stock or an ACCEL unit, you will have to place the injectors into the fuel rail and bolt them onto your manifold before you bolt the runners and install the injector harness. Be careful when installing the fuel injectors so as not to cut the O-rings. A small amount of oil on each O-ring will aid in the assembly. If you are using a factory 1985-89 plenum you will need to plug off the Cold Start Injector port, use ACCEL/DFI part number 74820 to do this.

NOTE: It is recommended at this point to use a hole saw (i.e.: Green Lee punches) to put two (2) 1-5/8" diameter holes in the firewall to accommodate the main wire harness. Refer to Figure D for hole locations.

Prior to bolting the throttle body to the plenum, we recommend cleaning the throttle blade, bore, IAC pintle and seat area. Depending on the age and prior use of a used throttle body, a significant amount of gum can accumulate in these areas and affect the idle characteristics of the engine.

Plumbing Connections:

- a) A vacuum line must be attached between the fuel pressure regulator and the right rear side of the plenum. Do not splice into this vacuum line; this can promote an erratic vacuum signal.
 - b) Use a 7/16" diameter hose to connect the oil breather on the valve cover to the right side of the throttle body, if so equipped. If not plug the corresponding port off on the throttle body.
 - c) Use a 5/32" diameter vacuum line from the bottom of the throttle body to the vacuum advance canister on the distributor. This is a ported vacuum signal. (This is only used with non-computer controlled HEI ignitions).
 - d) On the left side of the base manifold (on factory TPI and ACCEL base manifold) a barbed fitting is located. Use a 3/8" PCV hose to attach this to the PCV valve on the left valve cover. If you will not be using this, plug the barbed fitting.
 - e) Install a 3/8" diameter vacuum line from the rear barbed fitting on the plenum to the brake booster unit.
 - f) Finally, use a vacuum line to connect the MAP sensor to the right rear plenum fitting. Make sure not to splice into the MAP sensor vacuum line, this could promote inaccurate sensor readings.
-

III – MOUNTING THE ACCEL ECM

The ECM comes with three (3) mounting tabs designed for a #8 sheet metal screw. It is recommended to mount the ECM in the passenger side kick panel. If the kick panel has an air vent incorporated into it, **DO NOT** mount the ECM here. This is not waterproof and therefore, needs to be mounted in a location free of moisture. The alternate location is in the dash board area behind the glove box. **NEVER MOUNT THE ECM IN THE ENGINE COMPARTMENT!**

IV – INJECTOR HARNESS INSTALLATION

It is strongly recommended that this harness be installed prior to mounting the plenum. Refer to Figure A for routing the injector harness.

This ACCEL/DFI system is simultaneous double fire, therefore, an injector connector may be connected to any injector, but for your convenience, the connectors are paired in two's, similar to the way the injectors are mounted in the manifold.

Route the injector harness onto the manifold as shown in Figure A (Page 22). After properly aligning the injector harness onto the injectors, clip the connectors into place, making sure that the metal clips snap into place. After the main wiring harness has been installed, connect the injector harness round 5-pin female connector to the MWH's round 5-pin male connector.

V – MAIN WIRE HARNESS ROUTING AND CONNECTIONS

An overview schematic of the main wiring harness (MWH) is shown in Figure B (Page 23). The harness can be routed and connected as follows: Begin by connecting the 32 pin and 24 pin ECM connectors to the ACCEL/DFI ECM, making sure that the tabs snap into place. Then route the longer of the two legs through the drivers side firewall hole that you cut in step two, followed by the shorter of the two legs though the passenger side firewall hole. Continue pulling the harness legs through the firewall until the rubber grommets seat themselves in the firewall. Once the grommets have been properly seated into the firewall, each leg of the harness can be routed between the manifold and the valve covers.

The drivers side leg will contain connectors for the following:

- MAP (3-pin green male connector, refer to Figure B for mounting location)
- Computer controlled HEI (4-pin male black connector)
- ESC (1-pin female black connector)
- Air (2-pin Grey connector)
- Coolant (2-pin black connector)
- TPS (3-pin black male connector)

Connect each to the appropriate sensor using Figure B as a reference. If this is a ACCEL system for an LT-1 engine (74022-L), there will be an Opti-spark harness that will connect the Computer controlled HEI connector, a TPS extension harness, IAC motor adapter as well as adapter harnesses for the air and coolant sensors. If you are missing

any of these harnesses please contact your dealer immediately. Make sure to connect the switched +12 volt wire (long pink wire with a female spade connector) to a switched ignition accessory in the fuse box. The switched ignition accessory must maintain 12 volts during cranking, if it does not the vehicle will not start.

NOTE: If you are not controlling timing with the ACCEL/DFI ECM (using a non-computer controlled HEI, points distributor, etc.) you will not be using the computer controlled HEI connector (4-pin male black connector) or the ESC connector (1-pin female black connector).

The passenger side harness leg will contain the following sensor connections:

- Oxygen (3-pin female black connector)
- Injector (5-pin round white connector)
- Tach pick-up (1-pin brown connector)
- Fuel pump (bare lead, red wire with white stripe)
- IAC (4-pin square male black connector)

Connect each to the appropriate sensor using Figure B as a reference. If you need to lengthen the fuel pump wire to reach your fuel pump, make sure to use at least 14 gauge wire. Finally, be sure to connect both the positive and ground terminals of the MWH **DIRECTLY** to the battery. If you fail to do this intermittent and unusual problems may occur.

NOTE: If you are controlling timing with the ACCEL/DFI ECM (using a computer controlled HEI, TFI, etc.) the Tach pick-up will not be

used. If you connect the Tach pick-up and the Computer controlled HEI connector at the same time, your ECM will cancel both of them out, resulting in a no spark situation. In many cases this will also damage your ECM.

At this time you can connect your User Interface Module (UIM, or Power Tuner) to the MWH by connecting the 6-way connector (located near the ECM connectors) to the 6-way connector on the UIM. If you did not order a UIM there is nothing for you to do with the 6-way connector on the main harness. If using a UIM, mount the unit with two (2) #8 sheet metal screws or pan head screws with nuts, in a location convenient to the driver. See section XII for description.

VI – CHOOSING YOUR DISTRIBUTOR

NON-COMPUTER CONTROLLED IGNITION

If you are using a non-computer controlled HEI (prior to 1985), points style distributor, etc. the Tach pick-up (1-pin brown connector) must be used. Connect this lead to the negative side of your coil. If the brown connector must be removed for your application, be sure not to remove the 39K ohm resistor which is 3” from the existing connector.

NOTE: If you are using an aftermarket ignition enhancer box (i.e.: ACCEL 300+, MALLORY Hyfire) the MWH’s Tach pick-up connector **MUST** be connected to the enhancer box’s Tach output signal. It is also necessary to remove the 39K ohm resistor from the Tach pick-up wire. It is 3” from the end of the Tach pick-up lead. **DO NOT** connect this lead to the negative side of your coil if using an enhancer box, this can result in ECM damage.

ACCEL strongly urges the use of a good quality suppression wire such as ACCEL 300+ or ACCEL RFI Suppression Wires. We have encountered problems with various ignition wires available on the market such as helically wound or solid core not suppressing electrical noise. The use of these wires may interfere with the operation of the ECM. Further, some high energy aftermarket ignition units also produce electrical fields which will interfere with the ECM's operation. Use of these units is strictly at the risk of the owner. Call ACCEL for recommendations of ignition system compatibility.

The total advance you set the engine to will depend upon the engine you have. Vacuum advance should be controlled with the EGR port, which is located on the bottom of the throttle body. ACCEL/DFI recommends a distributor with adjustable vacuum advance. Once the total advance is set, connect the vacuum advance canister. Adjust the vacuum advance canister to maintain 20-26 degrees with a hot engine at 800 RPM. Again, this is ACCEL's recommendation, depending upon the compression ratio and cam profile, you may have to decrease timing to avoid detonation.

COMPUTER CONTROLLED IGNITION

If you are using a GM (F or Y body) computer controlled HEI distributor the MWH's four pin male black connector must be used. When using a Y body HEI, the four pin between the HEI and the MWH is compatible. However, if you are using a F body HEI, the four pin connection on the MWH will not plug directly into the distributor. In order to use a F body HEI you will need additional wiring. ACCEL/DFI's part number 74170 will allow you to connect your distributor to the MWH. You can also control timing with the ECM by using a magnetic pick-up distributor or crank trigger. In order to control timing with these ignition systems you

must get a modification done to your ECM (ACCEL/DFI part number 74043-I), this modification will come with the necessary additional wiring, but will not come with an ignition enhancer box that is required. If you will need this modification contact ACCEL/DFI for further instructions and a shipping address.

In order to set the initial timing, the ignition bypass connectors (white-one pin connector), incorporated into the HEI leg of the main wiring harness, must be disconnected. With the engine running hot at 800 RPM, manually adjust the distributor to 6 degrees BTDC. Once adjusted, reconnect the ignition bypass line. As soon as you connect the bypass line the timing will then be controlled by the ECM. The spark curve is preprogrammed into the ECM from ACCEL/DFI. It has as initial timing of 20 degrees BTDC and a total timing of 34 degrees BTDC in by 3000 RPM. The timing curves, as well as all other tables in the ECM, can be adjusted to better suit your engines requirements using ACCEL/DFI's calibration software CALMAP.

NOTE: If an aftermarket ignition enhancer box is used (i.e.: ACCEL 300+, MALLORY Hyfire) the Y body HEI can be wired as described by the manufacturer. However, if you are using an F body HEI or controlling timing with a magnetic pick-up distributor or crank trigger please reference figures E and F.

VII – FUEL PUMP MOUNTING AND HIGH PRESSURE LINE INSTALLATION

ACCEL/DFI has two high pressure fuel pumps currently available, an external mount fuel pump, part number 74701, which can support up to 500 horsepower @ 45 PSI. The second pump ACCEL/DFI offers (part number 74702) can support up to 840 horsepower @ 45 PSI, this fuel pump can be mounted in the fuel tank or on the frame rail. You can use part number 74710 to mount this pump onto your frame rail. Regardless of the fuel pump used, be sure to mount your fuel pump near the tank at a point below the tank level, in a protected area. System components must also be protected and shielded from exhaust heat and engine compartment heat as well as road damage.

Fuel Pump Wiring

The fuel pump requires a 12 volt source. If your vehicle was an EFI vehicle originally, and already has a fuel pump installed, you still MUST connect the +12 VDC side of the fuel pump to the ACCEL/DFI main harness (red wire with white tracer). The +12 VDC will come from fuel pump relay via the red wire with white tracer in the main harness. The fuel pump relay is already an integral part of the main harness and is controlled by the ECM, therefore no wiring is necessary for the relay. A pump will draw between 4 and 8 amps of current depending on size and fuel system pressure, so 14 gauge wire should be used from the pump to the red wire with white tracer. Also be sure to solder the connection between these two wires. The ground for the fuel pump can be at any clean, paint-free point on the chassis to the negative (-) terminal of the fuel pump. Make sure that wiring between the fuel pump and the engine compartment does not hang below the vehicle, interfering with rotating parts or become

exposed to excess heat.

Mechanical Pump Removal

If your engine was carbureted, be sure to either cap off the fittings on your mechanical pump or remove the pump and cover the opening with a block off plate.

High Pressure Fuel Filter Mounting

Locate the high pressure fuel filter at the outlet of the high pressure fuel pump on the frame rail. It is recommended to place a filter between the fuel tank outlet and the pump inlet if the pickup tube in the tank does not have a filter. Failure to do so can result in fuel pump damage. ACCEL/DFI high pressure fuel filters, part number 74720, requires 3/8" Saginaw fittings. If your fuel line does not have these fittings you can use part number 74721, these adapter fittings will fit the 74720 filter and allow you to use a 6AN fitting.

Routing High Pressure Fuel Hose

At this point the high pressure circuit of the fuel system can be plumbed (refer to figure G, Page 28). If the existing fuel supply line cannot sustain 150 PSI pressure (DFI recommends a fuel line rated to at least 330 PSI), then it must be replaced with high pressure fuel line/tubing. Remember, with a carburetor, your fuel system operated at about 6 PSI. However, with fuel injection, the system operates around 50 PSI of fuel pressure. Never take any chances. If in doubt, replace the hose. You will need a minimum of 3/8" ID supply line and 5/16" ID return.

Dual Fuel Tanks

It is important to note that for vehicles with either two fuel tanks and/or class "A" RV's it is highly recommended that a boost pump be installed in each tank and feed through a multi port switching valve, especially when operating in hot

climates. Boost pumps used on such vehicles as a 1985 Ford F-250 5.0L EFI will work well for this type of application. The switching valve from a 1984 Ford 6.9L Diesel or a 1986 Chevrolet C-10 (305 CID) will work well in dual tank applications. Dual tank equipped vehicles must be plumbed to return excess fuel to the tank which is supplying fuel to the EFI system to avoid tank overflow problems. The remotely activated dual tank three way valves described above will work well in these applications.

A NOTE TO THE INSTALLER

There seems to be a misunderstanding with some people that a fuel pump “produces pressure”. This is wrong. What actually happens is the pump produces fuel flow at a given system pressure which is dictated by the pressure regulator. The pressure regulator has a spring which is preset to provide a certain system pressure, i.e. 45 PSI. The regulator opens as the pressure in the fuel line increases due to the flow of fuel provided by the pump.

As the pressure drops, due to bypassing of fuel to the tank, the regulator closes at a pressure of 45 PSI (this pressure is variable on adjustable regulators). This process will begin again as pressure raises. Therefore, the pressure regulator is a dynamic modulating device which is always trying to seek its preset pressure.

Sending Unit Modifications

To install a return fuel line in your tank, remove the sender assembly from the fuel tank and drill a 5/16” hole through the top of the flange. Be sure to give yourself enough room to weld the tube into place; welding procedures are discussed later in this section. ACCEL/DFI Jumper Line Kit, Part Number 74731, will supply you with the this line as well

with other lines that you may need. Pre-bend a piece of 5/16” fuel line so that the in tank portion end is 2” from the bottom of the tank and away from the existing outlet tubes (see figure H). Ensure that the installation of this line does not interfere with any other components on the tank unit. Clean the unit with soap and water prior to the next step. Seal and secure the return line to the flange by welding or brazing with low heat so that flange warpage does not occur. Also make sure that applied heat does not damage the sending unit wires or wire seals. Clean the welded area and check for cracks or holes in the flange, tubes or welded area.

Check the condition of the filter sock on the pick-up tube. If the sock is torn or contaminated, replace it. Again, if you are not using a filter sock in your application then install a filter between the fuel tank supply line and the inlet side of your fuel pump.

Return Fuel Line Installation

If your vehicle was originally equipped with a carburetor, you **MUST** run a 5/16” diameter or larger return line from the engine (fuel pressure regulator) to the fuel tank. Some vehicles with carburetors came with 1/4” diameter return lines. This line is too small in I.D. and will create an unacceptable amount of back pressure in the fuel line, thus causing a rich condition. Using good judgment install a fuel line from the pressure regulator outlet to the fuel tank with restriction free bends in protected areas (refer to figure H). The fitting at the pressure regulator is a #5 AN fitting and ACCEL/DFI recommends a #5 AN to 5/16” Aeroquip stainless fuel line connector to connect the 5/16” return fuel line.

ACCEL/DFI recommends using a good fuel line for supply and return line plumbing, such as a double braided stainless steel teflon AQP by Aeroquip.

VIII – MOUNTING THE OXYGEN SENSOR

The ACCEL/DFI system comes with an oxygen sensor and a M18 X 1.5 hex nut. This nut is to be welded to the collector (preferably away from the passenger side) of the exhaust header, if you are not using headers, please refer to figure I. You will want to mount this closest to the header flange (or exhaust manifold) without interfering with exhaust connecting flange.

Prior to mounting the nut, drill a perpendicular 5/8" diameter hole in the exhaust pipe or header collector.

IX – AIR CLEANER ASSEMBLY

If using a stock TPI or 58mm throttle body, use ACCEL Powerfilter part number 74550. If you are using a 750 CFM or 1200 CFM throttle body, these throttle bodies have a 5-1/8" filter surface, therefore any carburetor style air cleaner will work.

X – TPS ADJUSTMENT

At this point all the electrical connections should be made between the sensors, computer, and optional equipment. Keep in mind that you will have at least one extra connector that will not be used on the main wiring harness. Now connect the positive terminal to the positive side of the battery, and the ground wires (see figure B or figure C depending on application) to the negative battery terminal.

Prior to adjusting the TPS the throttle blades need to be initially set. This can be done by backing the throttle stop screw out so the throttle blades bottom out in the bore. ACCEL/DFI has found a good starting position on a stock throttle body to be four (4) turns in, once the screw makes contact with the throttle blade tang. Again, this is just a starting point and every application will vary. Next loosen the screws that secure the TPS.

With the motor running, measure the voltage across pins A & B of the TPS with a volt meter. Rotate the sensor until +0.5 volts is shown. This can also be done using CALMAP, consult your CALMAP users guide.

XI – STARTING THE VEHICLE

Turn the ignition key to the run position. Do not crank yet. The fuel pump should run for two seconds, then shut off. Now turn the ignition key off. Repeat this procedure of turning the key on and off four (4) times. Again, listening carefully for the fuel pump. This is needed to prime the fuel delivery system. The best way to check is to connect a fuel pressure gauge to the shroeder valve on the passenger side fuel rail. ACCEL/DFI offers gauges for certain applications, check your application with one of our dealers. Now check for fuel leaks along the entire vehicle length. Crank the engine. After the engine starts the engine should fast idle and the speed will decrease as the coolant temperature heats up. If the engine does not start after ten seconds of cranking, listen or feel for the injectors opening and closing, insure the following:

- a) All electrical and mechanical connections are made securely.
- b) There are no fuel leaks. The cold start valve block off kit was properly installed and tightened (if this applies to your application).
- c) The fuel feed line is pressurized with fuel. The most common problem is the fuel pump is wired backward. On the ACCEL pumps, the (+) and (-) designations are casted in the pump adjacent to the terminals. If the ACCEL 74702 pump is wired backward, it will run backward.
- d) Insure that the engine timing is properly set. After the vehicle starts, check for fuel leaks along the entire length of the vehicle.

XII – OPTIONAL ITEMS

User Interface Module (UIM, part number 74500)

This option allows the driver to change the three dimensional fuel table while the engine is running. The UIM contains two potentiometers for increasing or decreasing the amount of fuel supplied to the engine during idle and WOT. The idle potentiometer provides the user with the ability to increase or decrease the amount of fuel at idle and part throttle fuel by 10%. The WOT potentiometer comes into play only when the throttle is fully opened. The percent increase and decrease is 25%. The UIM does not change the amount of fuel delivered during cranking.

The UIM must remain connected to the main wiring harness after adjustments are made to the ECM. If it is disconnected, the ECM will automatically default back to its preset values.

If your engine requires a somewhat different calibration than is noted on the ECM, or you are calibrating a unique engine combination, use the ACCEL/DFI Serial Communications Interface option, CALMAP (Part Number 74990-S with 5ft cable, 74990-L with 25ft cable). This software will allow you to customize the Fuel and Timing curves as well as all other parameters in the ECM.

F-BODY HEI DISTRIBUTOR KIT (PART NUMBER 74170)

This kit will allow you to use a F-body HEI to control timing with an ACCEL/DFI system. The kit consists of a jumper harness that goes between the MWH and the distributor as well as one that goes between the distributor and your coil. In addition to these there is also a connector that will go between your coil and a power source.

**KNOCK SENSOR HARNESS KIT
(PART NUMBERS 74174- S.B. CHEVY 74175 B.B. CHEVY)**

The knock sensor harness kit allows the end user to incorporate a GM knock sensor to detect detonation and automatically retard the spark timing. The kit comes with a harness which interfaces between the GM ESC Module, GM knock sensor and ECM. Since these sensor are calibrated for Chevrolet engines only they can only be used on Chevrolet engines.

FAN CONTROL KIT (PART NUMBER 74171)

This kit includes a harness with integral relay that interfaces between the ECM and the fan. This kit allows you to turn on an electric fan at a given engine temperature via CALMAP. This kit does not include a fan.

**TORQUE CONVERTOR LOCKUP KIT
(PART NUMBER 74172)**

This kit includes a harness with integral relay that interfaces between the ECM and 700R4 Converter Lockup connector. This kit allows you to lockup and unlock the converter at a prescribed speed (RPM), and throttle position (TPS) using the CALMAP software. Be advised that if your 700R4 is in a truck (or came out of a truck) that some additional wiring and an extra relay will be required.

**NITROUS CONTROL KIT
(PART NUMBERS LISTED BELOW)**

S.B. Single Stage Part Number 74172

B.B. Single Stage Part Number 74182

S.B. Multi Stage Part Number 74183

B.B. Multi Stage Part Number 74181

This kit includes a harness with integral relay that interfaces between the ECM and the nitrous solenoid. The kit also comes with a toggle switch, nitrous plate (which bolts between the plenum and the throttle body), and the necessary lines and fittings. This kit enables you to control a nitrous solenoid and at the same time controls spark timing and fuel enrichment.

XIII – TROUBLE SHOOTING GUIDE

The following are some common problems we have encountered with various installations.

Injectors not firing (clicking) - the vehicle will not start:

- Usually due to a low battery. Voltage must be above nine volts during cranking to activate the ECM.
- Injector harness not connected to the main wiring harness.
- Short in either pin P1-C7 or P1-C8. Check continuity to battery positive and negative wires with an OHM meter.
- Tach wires to positive side of coil instead of negative.
- P1-D7 (long pink wire with female spade connector) not receiving 12 volts during cranking. Usually due to connecting this wire to a voltage source that is disabled during cranking.

Runs rich at idle:

- Vacuum line to fuel pressure regulator not connected.
- MAP sensor vacuum line pinched.
- UIM idle knob turned all one way.

Runs rich all the time:

- Wrong injectors for the application.
- Return fuel line is too small/restricted.
- Calibration in the ECM is wrong for the application.

Engine cranks a while before starting:

- +12V and ground terminals not connected directly to battery.
- Fuel pump is not priming the fuel system.

If you are experiencing problems please contact your ACCEL dealer or feel free to contact ACCEL's technical service line and talk to an ACCEL/DFI technical representative. ACCEL's technical phone number is: 1.216.398.8300 EXT: 500.

Written by Charlie Trombley

Figure A

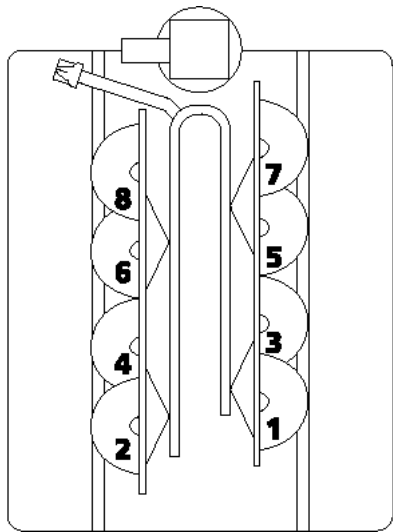
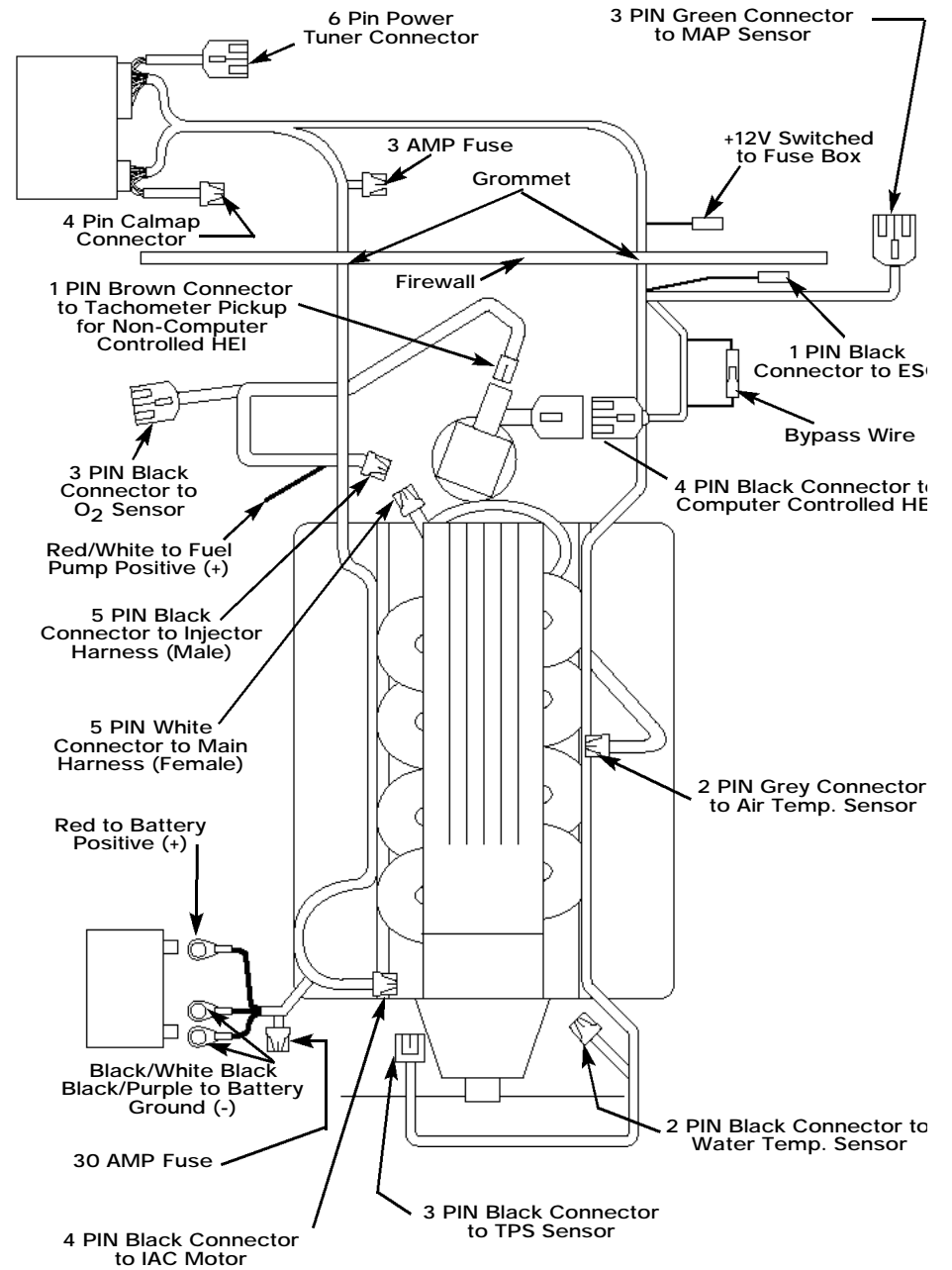

Figure B



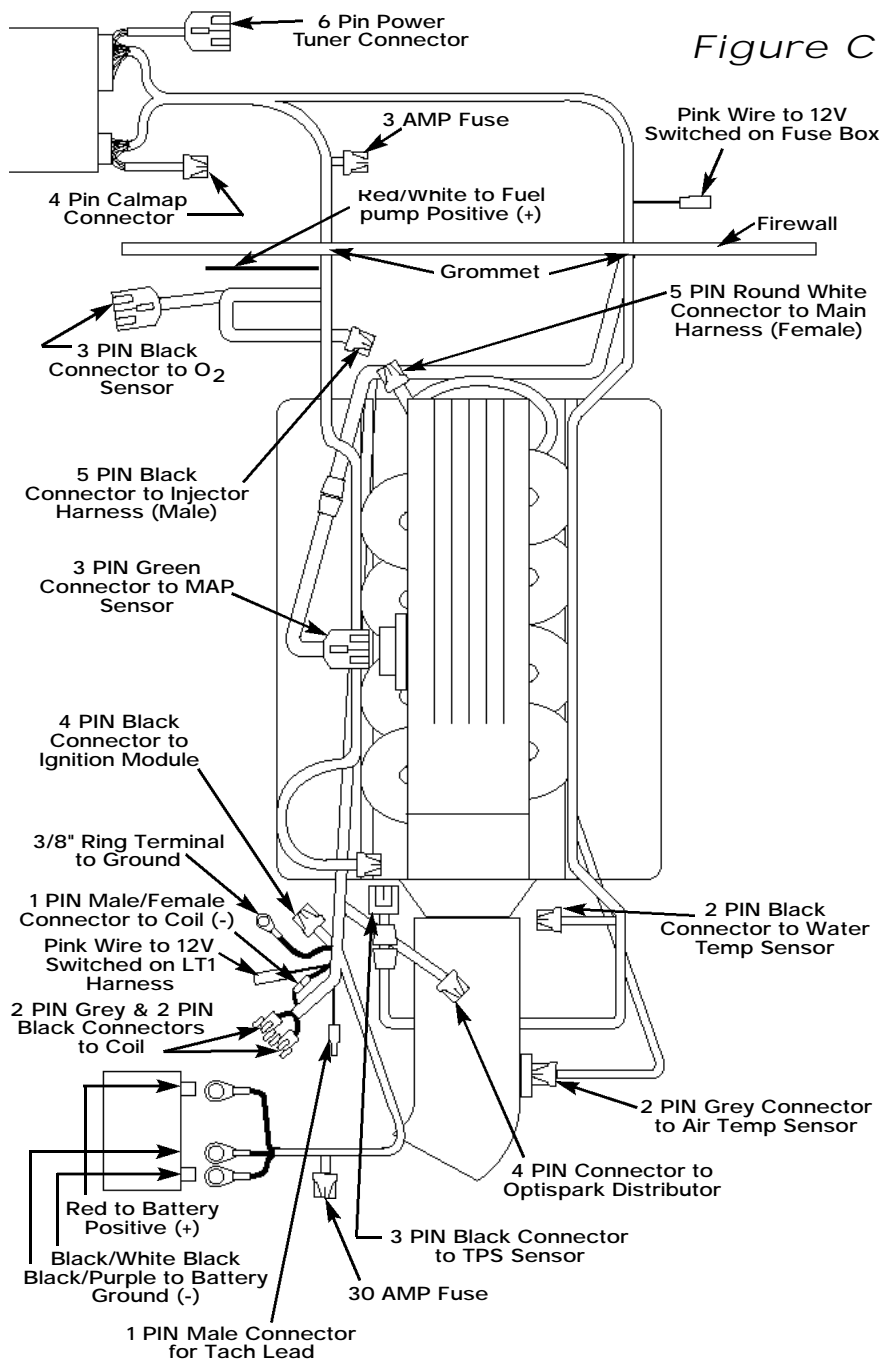

Figure D

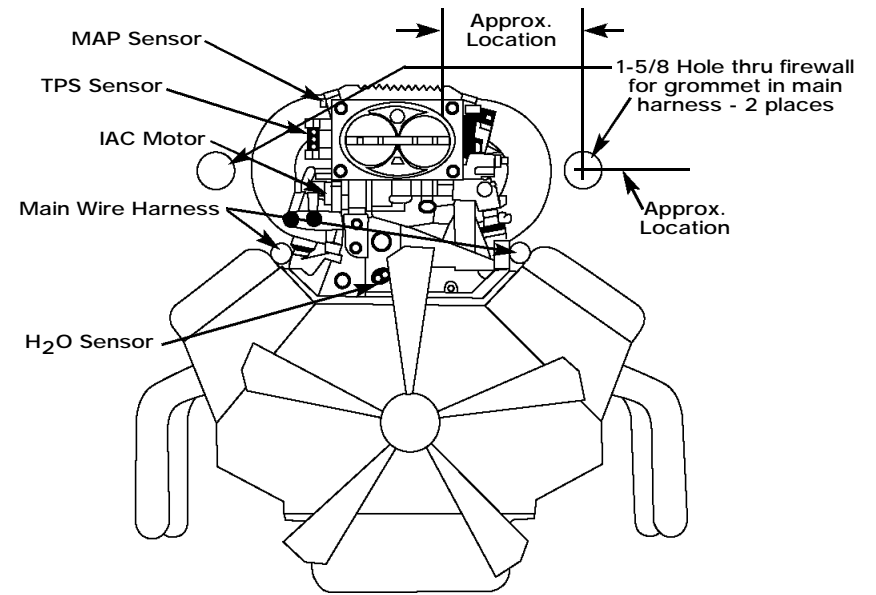

Figure E

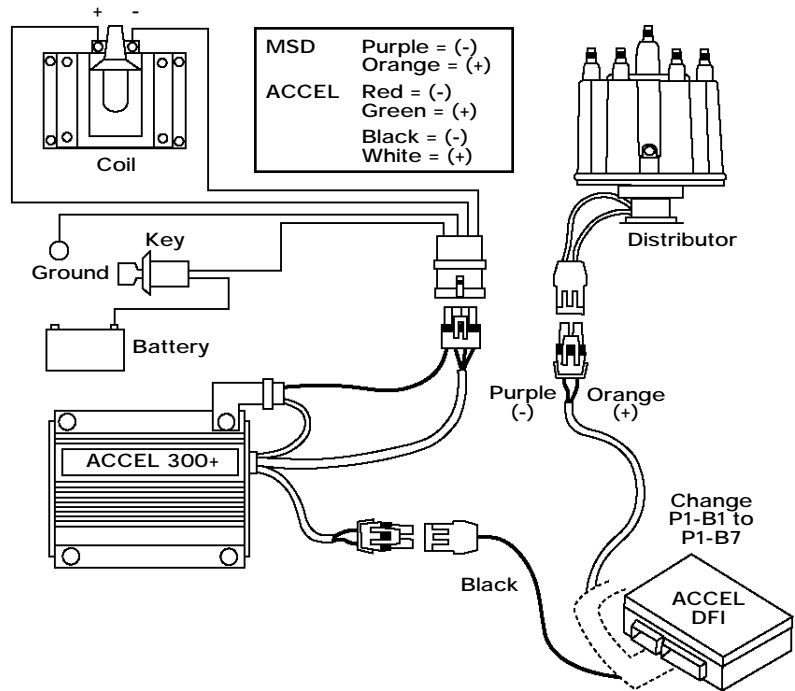

Figure F

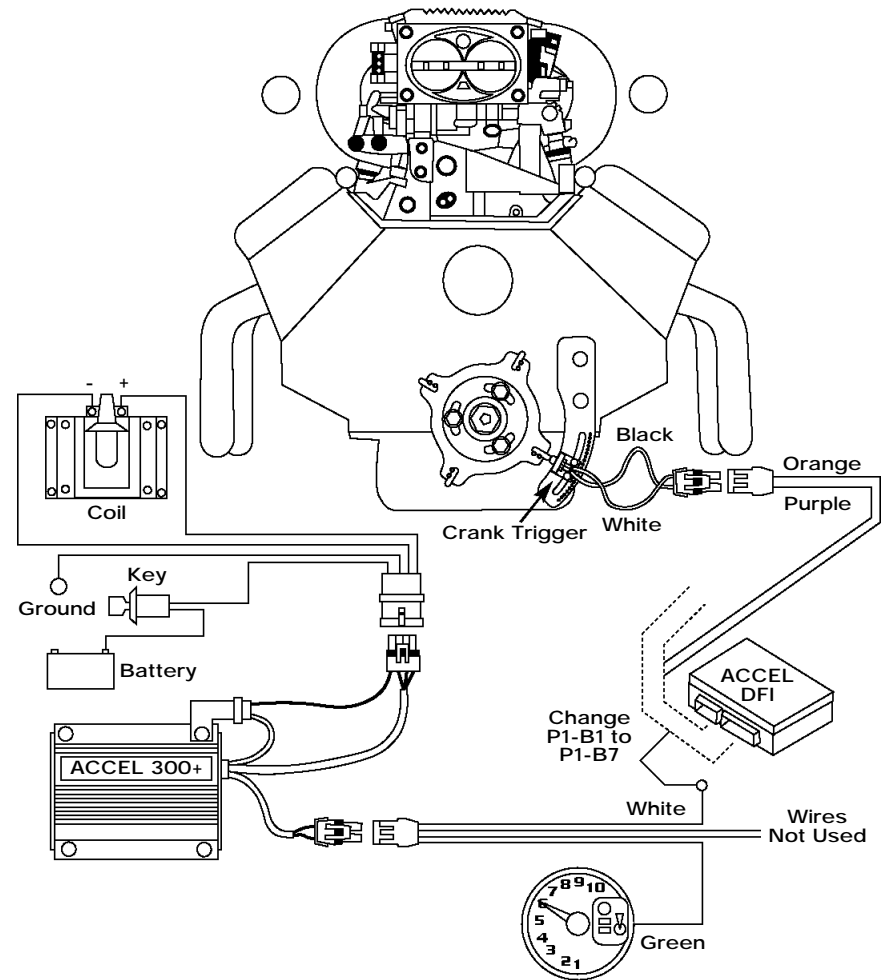

Figure G

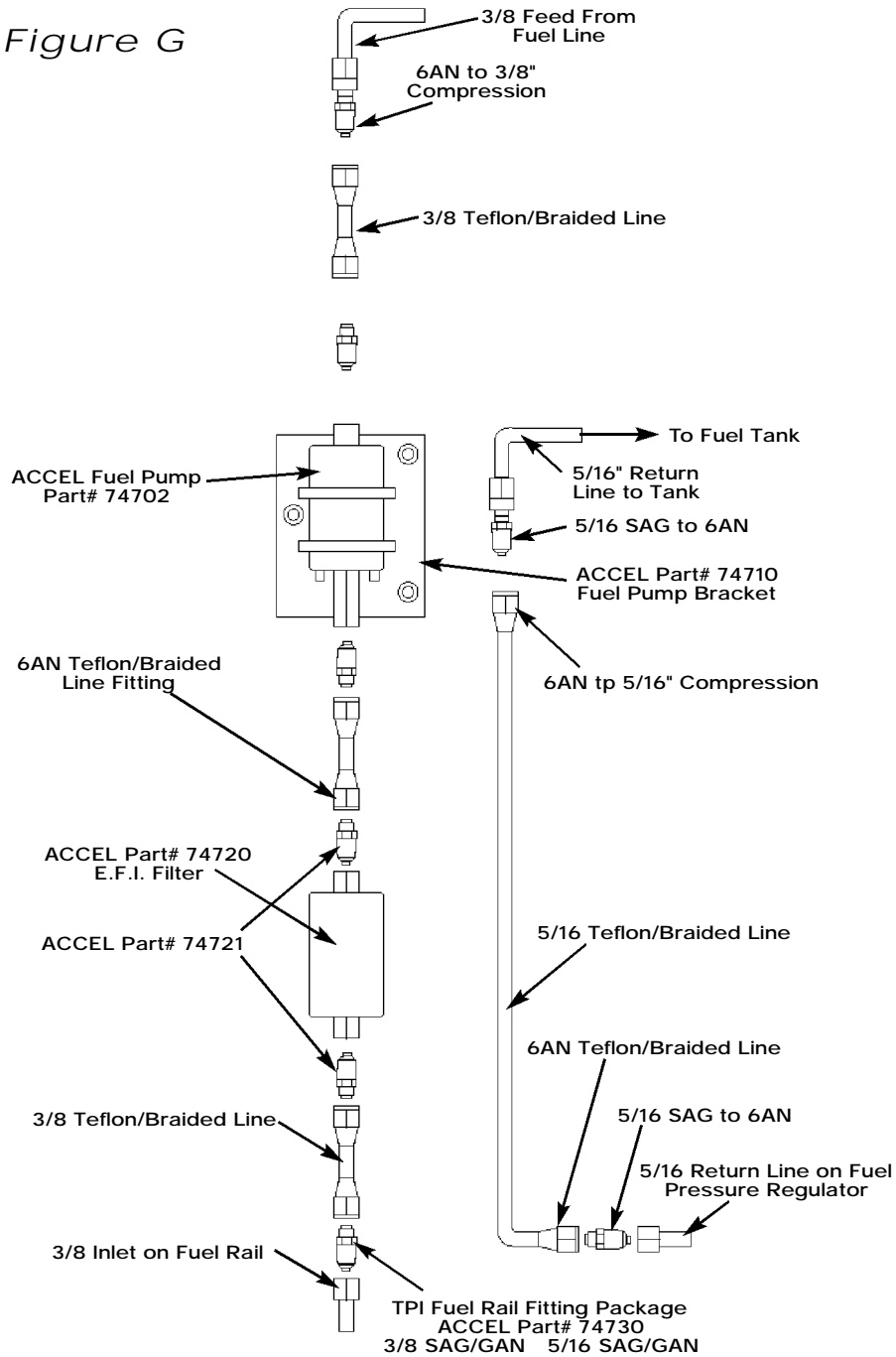

Figure H

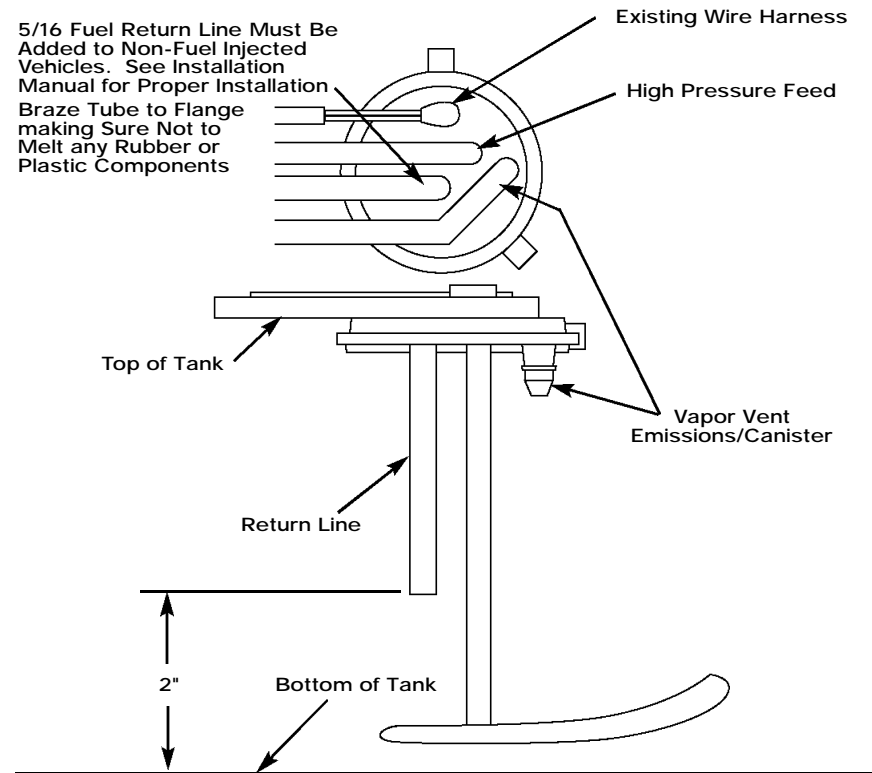
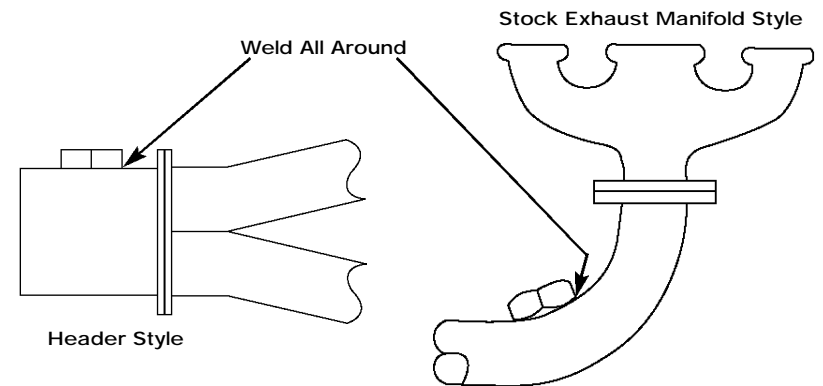

Figure I



NOTE: If using ACCEL Pump Part #74701, please contact ACCEL/DFI Technical Service for proper plumbing instruction.



Cleveland, Ohio
216.398.8300
www.mrgasket.com